



282 Series Lamp with Conversion Cable

#SO282ARWM2LR450

www.ledautolamps.com



FEATURES

- Helps solve canbus vehicle errors when fitting LED's
- Terminated with DTO4-6P male connector
- Includes 2 prewired load resistors
- ECE approved lamp
- IP67 rated
- 5 year warranty

DIMENSIONS

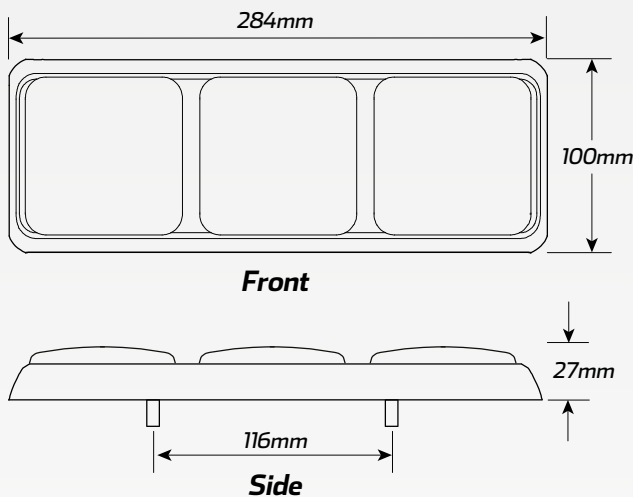

Total Dimensions:

- Length: 284mm
- Height: 100mm
- Width: 27mm



12V

IP67

ECE/ADR

5 YEAR WARRANTY

FITTING INSTRUCTIONS

Horizontally surface mount using bolts in back of lamp, run wire and plug through 10mm hole in fixing surface.

Please refer to ADR 13/00 for mounting instructions.

TECHNICAL SPECIFICATIONS

LED Quantity	• 48 SMD LED's
Voltage	• 12V only
Cable Length	• 45cm, 2 x LR12, DTO4-6P male plug
Function	• Stop/Tail, Indicator, Reverse
Dimensions	• 284mm W x 100mm H x 27mm D
IP Rating	• IP67 rated
Warranty	• 5 year warranty

Amperage	<ul style="list-style-type: none"> • Stop: 0.33A @ 13.8V, 0.17A @ 28V • Tail: 0.03A @ 13.8V, 0.3A @ 28V • Indicator: 0.30A @ 13.8V, 0.17A @ 28V • Reverse: 0.24A @ 13.8V, 0.13A @ 28V
Approvals	<ul style="list-style-type: none"> • Stop/Tail: ADR Cat 49/00 CRN 47008, ECE R1-S1-E9-02.11736 • Indicator: ADR Cat 6/00 2A CRN 47015 ECE 2a-E9-01.11736 • Reverse: ECE AR-E9-00.11736 • CTA: CTA-060094