



**Heavy Duty 50A  
Anderson Cover**  
#SY50COVER

www.trailervision.com.au

**DESCRIPTION**

50A Anderson plug surface mount cover.

Heavy duty 50A Anderson connector cover for surface mount applications. Features a front rubber seal within the latch and a spring locking system, providing a weather and dust protection from the elements. Rubber sealed ends, clamps down the wiring, preventing dust from entering through the rear of the cover.

Suitable for genuine Anderson & Anderson style connectors.



**TECHNICAL SPECIFICATIONS**

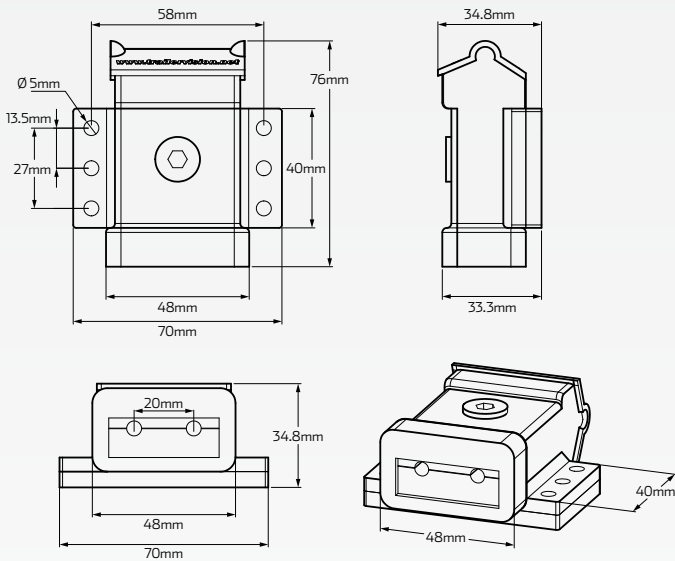

<b>Applications</b>	<ul style="list-style-type: none"> <li>50A Anderson style connectors (Not included)</li> </ul>
<b>Features</b>	<ul style="list-style-type: none"> <li>Rubber seals at the front and rear of the cover, ensuring protection from dust &amp; debris</li> </ul>
<b>Mounting</b>	<ul style="list-style-type: none"> <li>Surface mount</li> </ul>
<b>Housing Material</b>	<ul style="list-style-type: none"> <li>Nylon PA 66</li> </ul>
<b>Cover Pin Material</b>	<ul style="list-style-type: none"> <li>Stainless steel</li> </ul>
<b>Spring Material</b>	<ul style="list-style-type: none"> <li>Stainless steel</li> </ul>
<b>Bolt Material</b>	<ul style="list-style-type: none"> <li>Stainless steel</li> </ul>

**PART NUMBERS**

Part Numbers	Colour	Descriptions
SY50COVER	<ul style="list-style-type: none"> <li>Black</li> </ul>	<ul style="list-style-type: none"> <li>Heavy duty black 50A Anderson style cover. Suitable for Genuine &amp; Anderson style connectors.</li> </ul>
SY50COVERRED	<ul style="list-style-type: none"> <li>Red</li> </ul>	<ul style="list-style-type: none"> <li>Heavy duty red 50A Anderson style cover. Suitable for Genuine &amp; Anderson style connectors.</li> </ul>